



<b>1 -</b>	.....	<b>7</b>
1.1.	.....	7
1.2.	.....	7
1.3.	.....	10
1.4.	.....	10
1.5.	DI GI @WAVE 280 .....	11
1.6.	DI GI @WAVE™ 400/500 .....	11
1.7.	.....	12
1.8.	DI GI @WAVE .....	13
1.9.	.....	13
1.10.	.....	13
<b>2 -</b>	.....	<b>14</b>
2.1.	.....	14
2.2.	.....	14
2.3.	.....	14
2.4.	.....	14
2.5.	.....	14
2.6.	.....	15
<b>3 -</b>	.....	<b>16</b>
3.1.	.....	16
3.2.	.....	17
3.3.	.....	18
3.4.	.....	23
3.5.	.....	29
3.6.	W000241701 .....	33
3.7.	N2 REF. W000266590 .....	34
3.8.	PC REF. W000055081 .....	37
3.9.	MUXAL REF. W000055037 .....	39
3.10.	.....	43
	.....	<b>44</b>
3.11.	500CDR W000055083 .....	44
3.12.	DVR 500 W000055087 .....	44
3.13.	DV-R 600 HD W000055068 .....	46
3.14.	.....	46
3.15.	.....	47
3.16.	(DI GI @WAVE 280) .....	47
3.17.	(DI GI @WAVE TM400) .....	48
3.18.	(DI GI @WAVE 500) .....	48
3.19.	.....	48
	.....	<b>49</b>
3.20.	REF. W000055077 .....	49
3.21.	CAD REF. W000055040 .....	49
3.22.	REF. W000055046 .....	49
3.23.	REF. W000055048 .....	49
3.24.	W00005501 .....	50

3. 25.	REF. V000345009.....	50
3. 26. A1	REF. V000241701.....	51
3. 27.	CAD REF. V000264590.....	51
3. 28.	REF. V000055061.....	51
3. 29.	REF. V000264842.....	51
3. 30.	REF. V000261664.....	51
<b>4</b>	.....	<b>52</b>
4. 1.	.....	52
4. 2.	.....	52
4. 3.	.....	53
<b>5 /</b>	.....	<b>54</b>
5. 1.	.....	54
5. 2.	.....	56
5. 3.	DIGI @WAVE 280 .....	60

# 1 -

## 1.1.

DIGI@WAVE :

MIG-MAG ; ( , , ), ( 20A 400A ( ) )

☞

☞ *Inverter - DGW500*

☞

☞ 0.6mm 1.6mm

☞

DV500 CDR DVR 500 DV-R 600 HD

1 280

## 1.2

DIGI@WAVE

☞ " " " lisse"

☞ " " " SSA"

MIG ( )

a) " " " lisse"



" "

" "

:" " 1mm  
" "

b) " " " SSA"



" "

SSA

DI G @WAVE

DI G @WAVE

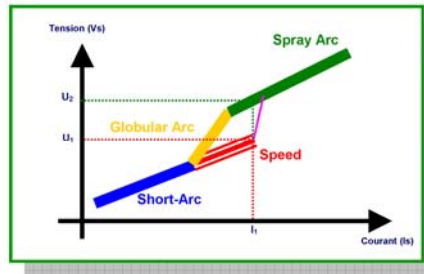

DI G @WAVE



- ⦿
- ⦿
- ⦿
- ⦿
- ⦿
- ⦿
- ⦿

25%

\_\_\_\_: CO2 " " " "

c) MIG

MIG

MIG

- ⦿
- ⦿
- ⦿

Q  
Q  
Q

50%

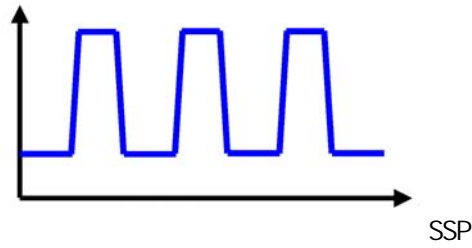

DIG@WAVE

"

"

\_\_\_\_\_

1mm      MIG      1mm      Arcal - 12 or Noxal i c- 12  
 30A      DIG@WAVE      TIG

d)

MIG      SSP  
 1      1.2mm



Q  
Q  
Q



e)



4mm

### 1. 3.

#### ANNEXE

	SD ZN(ATAL 5) SD 400(ATAL 5, 002)
---	-----------------------------------

☞

=  
=  
=

	ARCAL 21	ARCAL 14	ATAL 5A	ATAL 5	TERAL 23	ELOXAL 35
(1)						

	ARCAL 1	ARCAL 31	ARCAL 32	ARGON NERTAL	I NARC 9
(1)					

	ARCAL 12	ARCAL 121	ARCAL 129	NOXALIC 12
(1)				

(1)

### 1. 4.

6

\*

1.

5

DIGI@WAVE 280

2

DIGI@WAVE 280

3.

DIGI@WAVE 280

4.

5.

5

6.

\*

### 1. 5. DIGI@WAVE 280

(*see* 1)

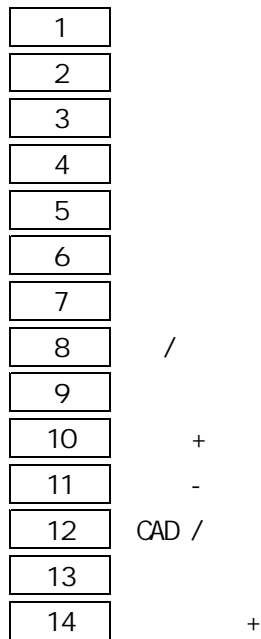

### 1. 6. DIGI@WAVE™ 400/500

(*see* 1)

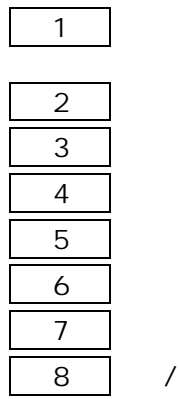

9	
10	+
11	-
12	CAD /
13	
14	
15	1

1.7.

	<i>DIG@MVE</i> 280 - REF: V000055011	<i>DIG@MVE</i> ™ 400 - REF: V000055015	<i>DIG@MVE</i> 500 REF: V000055020
3	400 V	400 V	400 V
MIG	60% 100%	- 21. 4A	34. 5A 29. 8A
	60% 100%	- 22. 3A	45. 2A 38. 9A
	50/60Hz	36. 2A 31. 3A	44. 9A 41. 2A
MIG	60% 100%	- 14. 8kVA	50/60Hz
	60% 100%	23. 9kVA 20. 6kVA	31. 3kVA 27. 0kVA
	60% 100%	25kVA 21. 6kVA	30. 9kVA 28. 5kVA
	21. 4A MIG / 22. 3A EE	29. 8 A MIG / 31. 3A EE	38. 9A MIG / 41. 2A EE
	113V	113V	113V
	20A - 280A	20A - 400A	20A - 500A
100%	MIG: 280A / 28V EE: 280A / 31. 2V	MIG: 350A / 31. 5V EE: 350A / 34V	MIG: 450A / 36. 5V EE: 450A / 38. 0V
100%	- -	- -	MIG: 420A / 35V EE: 420A / 36. 8V
60%	- -	MIG: 400A / 34V EE: 400A / 36V	MIG: 500A / 39. 0V EE: 480 A / 39. 2V
60%	- -	- -	MIG: 470A / 37. 5V EE: 450A / 38. 0V
	I P 23S	I P 23S	I P 23S
	H	H	H
	EN60974- 1/EN60974- 10	EN60974- 1/EN60974- 10	EN60974- 1/EN60974- 10

	10cm
---	------

	500A	ref : Z90000159
---	------	-----------------

	IP	
	2	12 5mm
	1	
	3	60
	S	

### 1.8 DIG@WAVE

	4
	0.5 ⇒ 25 m/min
	0.6 ⇒ 1.2 mm
	" "

### 1.9.

	400V
	230 V
	4
	4.5 l / min



### 1.10

	X X		
DIG@WAVE 280	845 X 380 X 855mm	76kg	95kg
DIG@WAVE™400	845 X 380 X 855mm	91kg	110kg
DIG@WAVE 500	845 X 380 X 855mm	91kg	110kg

2 -

2 1.



 10cm

 : 10

2 2

DIG@WAVE 400V

⇒ 50 60 Hz

" 3 + "

2 3.

[Empty rectangular box]

MIG

2 4.

2 5.

DIG@WAVE 280



/

☞

15 20 /min

DIG@WAVE TM100 / 500

☞

☞

☞ /

☞

☞

15 20 /min



2 6

DIG@WAVE 280

DIG@WAVE TM100/500

3 -

3.1.

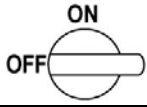

DIGI@WAVE 280

a)



15



b)



1m/min,

12m/min



DIGI@WAVE™ 400 / 500

a)

b)

GRE" "



GRE

2 1

c)



d)

e)



- 1
- 2
- 3
- 4
- 5
- 6

OK

FAV OK

5 10

SD400, SAFDUALZN

### 3.2

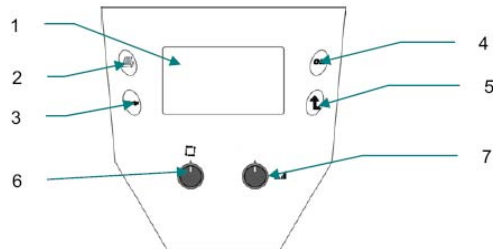

- 1
- 2
- 3
- 4
- 5
- 6
- 7

a) / /

6

6

⇒ " OK" 4  
 ⇒ 7  
 ⇒ " " 5

b) " " 3  
 " " "

c)  
 DIG@WAVE PC  
 TRIMTRIO - RS232 ref : ZV000262747

SET-UP SET CONFIGURATION PRINTING

1200 57600  
 0.2s 5s 0.2

8

1

PC

1200  
 PC

8

1



SET-UP CYCLE U Vfil

### 3.3

Ith, Uth Epth:

/

± 15%

⇒

⇒

SET UP		Prg : 0	
Vfil	: 3.0	Uth	: 9.6
Lg arc	: 0.0	lth	: 18.6
ReglageFin	: 0	Ep th	: 4.0
CrNi	1.2	Ar	CO2
		<b>2T</b>	



⇒

⇒

( )

SET UP		Prg : 0	
Vfil	: 3.0	Uth	: 9.6
Lg arc	: 0.0	lth	: 18.6
ReglageFin	: 0	Ep th	: 4.0
CrNi	1.2	Ar	CO2
		<b>2T</b>	

⇒

⇒

SET UP		Prg : 0	
Vfil	: 3.0	Uth	: 9.6
Lg arc	: 0.0	lth	: 18.6
ReglageFin	: 0	Ep th	: 4.0
rNi	1.2	Ar	CO2
		<b>2T</b>	

MIG-MAG

DI G @WAVE

5

⇒

⇒



DI G @WAVE







/ /

/ /

⇒

/ /

⇒

SET UP		Prg : 0	
Vfil	: 3.0	Ith	: 96
Lg arc	: 0.0	Uth	: 18.6
ReglageFin	: 0	Ep th	: 4.0
CrNi	1.2	Ar CO2	
			<b>2T</b>
			

\_\_\_\_\_

\_\_\_\_\_

\_\_\_\_\_

DIGI@WAVE

- 
- 
- 
  
- 
- 
- 
  
- 
- 
-

- 
- 

2t, 4t,

⇒

⇒ 2t, 4t

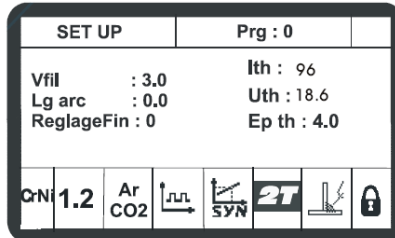

A1-A2

2T

A3

"væl di ng cycl e"

"OK"

"general

cycl e"

"væl di ng posi ti on"

CDP

"OK"

CDP

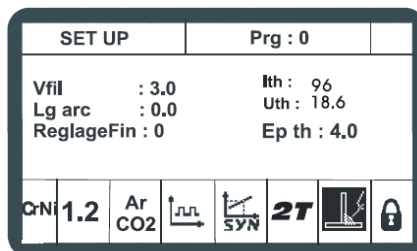
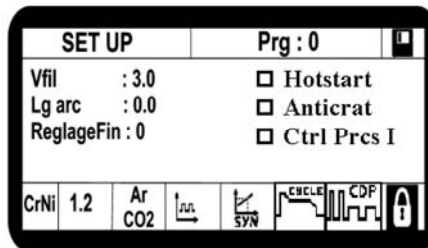

⇒

⇒ "OK"

⇒

6

" " " "

"OK"



3.4.

>2.1

			R L R=8, L=6 R L GRE
		MIX	VOIRCI DESSOUS
		MIX	VOIRCI DESSOUS
		Mixal I	VOIRCI DESSOUS
	GRE		/ / I U  1 99  2.2 INDAF  /  /  PRG " "
		I	I
		U	U
		I	I

--	--	--

PC	USB	/
	CAD	
	N2 / N3	
	MUXAL	
	MICRO	

a) " "

0 1 2 3

\* RI / RI / RI /

b) " muxal unit"

muxal unit /

" "

\*Muxal /

N	B	muxal	A2	A2
---	---	-------	----	----

c) muxal unit"

\*\* /

/

mux /

mux /

mux /

mux /

mux /

Ext mux /

N	B	**	"	/	"
---	---	----	---	---	---

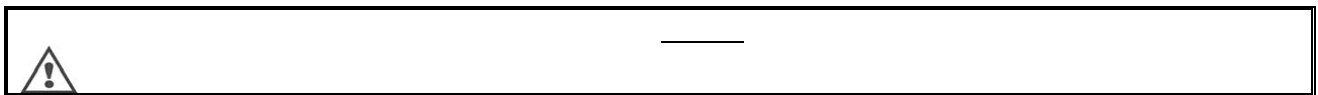

Vfil,Uarc

⇒ 0 10 0.1

⇒ 0 10 0.1

ANNEX2

0 10

" ACTIVE"



0  
4T                    2  
⇒  
⇒

1-2-3            0 2T  
/                    "  
                      "

CDP

CDP

- ⇒
- ⇒
- ⇒
- ⇒

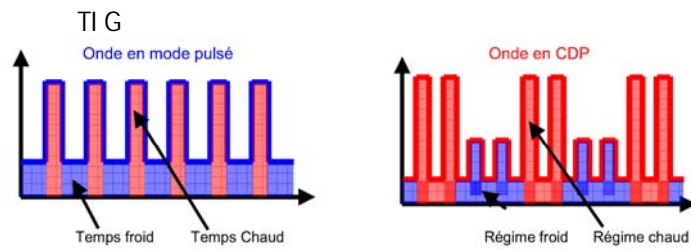

CDP

" = "

" 0.2s  
"

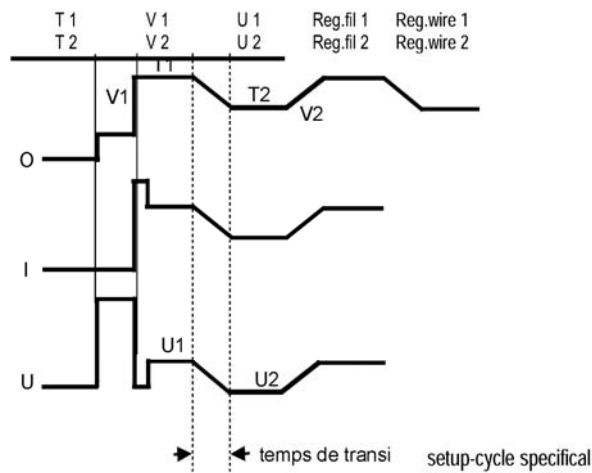

/  
ANEX 2  
/

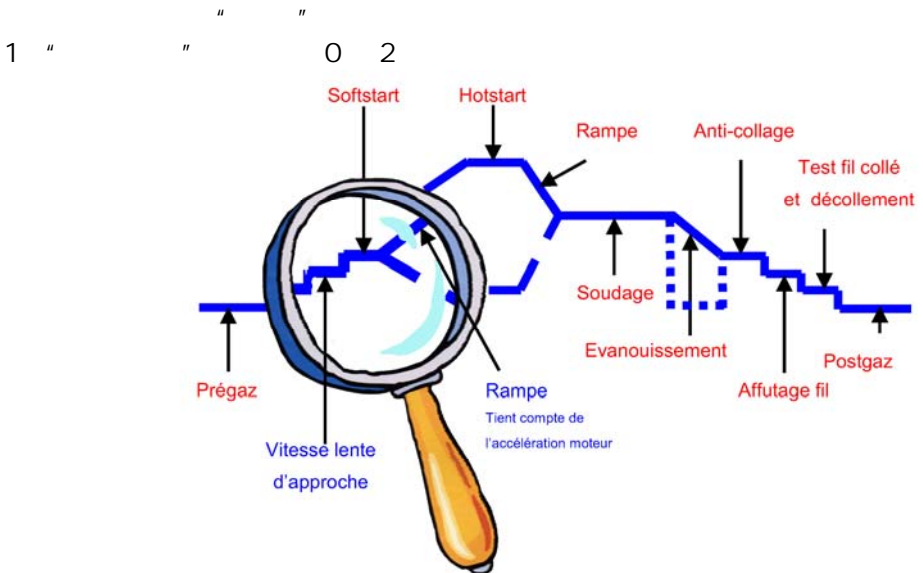

/ / / / / /  
⇒ / ns  
⇒ (ns) /  
⇒ /  
⇒ /

pour une vfil = 5ml/min

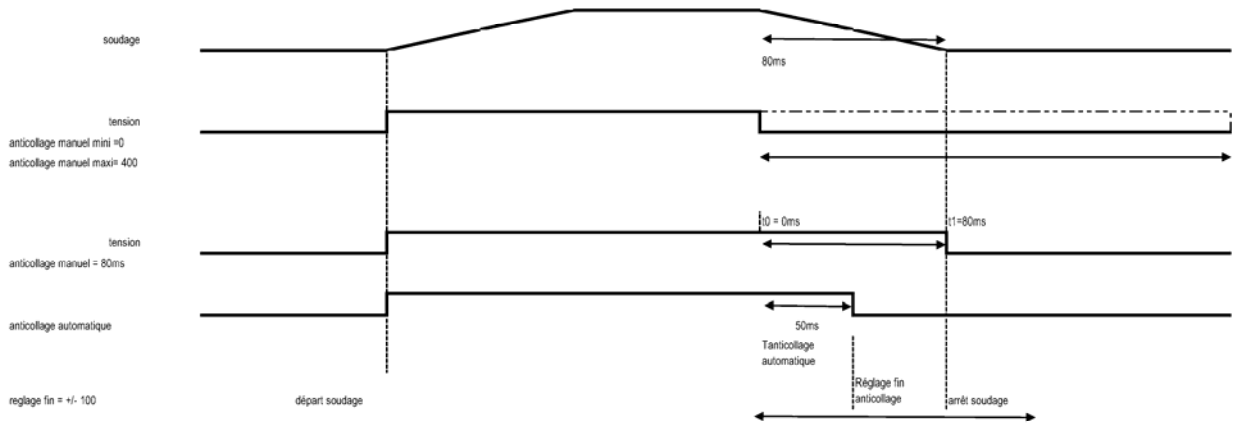

Anticollage automatique =  $(\sqrt{vfil} \cdot 10)(ms) + \text{reglage fin anticollage}(ms)$

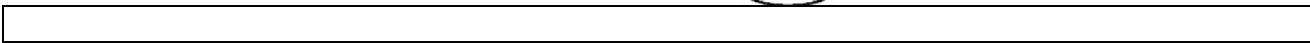
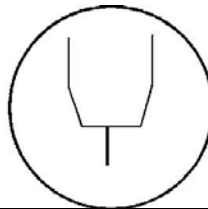

/  
/

OK

OK

3

- ⇒
- ⇒
- ⇒

/

± X%  
± X%

Rl

\* \* " "  
\* \* " "

Rl

ns

Rl

0 10V 0 100%

A2

3

3 I I U I U

T = I IM U I IM  
 U  
 $I_{min}(A) / I_{min}(A) / U_{min}(V) =$   
 $I_{max}(A) / I_{max}(A) / U_{max}(V) =$

$I_{max} =$   
 $I_{min} =$   
 =

→

1.  $I > I_{max}$   $t_1$   $I_{max} < T$   
 2.  $I < I_{min}$   $t_2$   $I_{min} > T$

- T =
- T = t1 + t2
- t1 < T =
- t2 > T =
- 

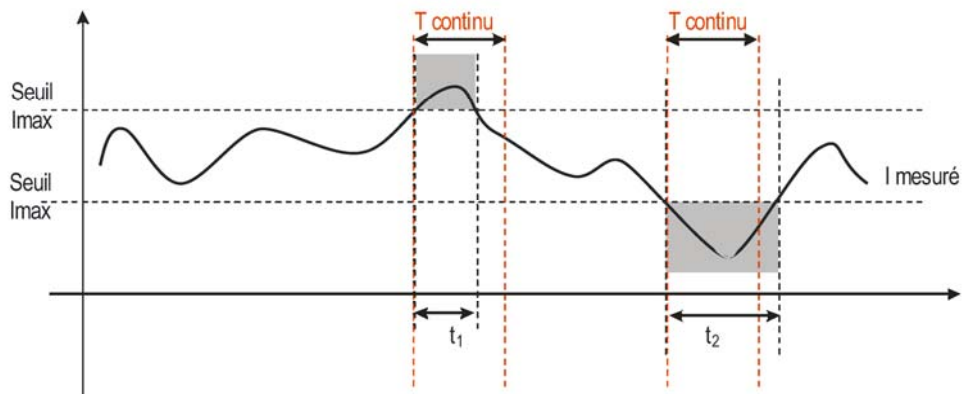

300ns

500ns

= 1

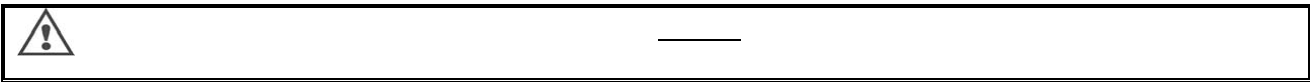

### 3.5.

MIG-MAG

- ⇒ 2
- ⇒ 2
- ⇒ 2
- ⇒ 2
- ⇒
- ⇒
- ⇒
- ⇒ 4
- ⇒ 4

2

2

" = "

2

" = "

0 - 75%

2

2

=

2

" = "

" "

=

=

4

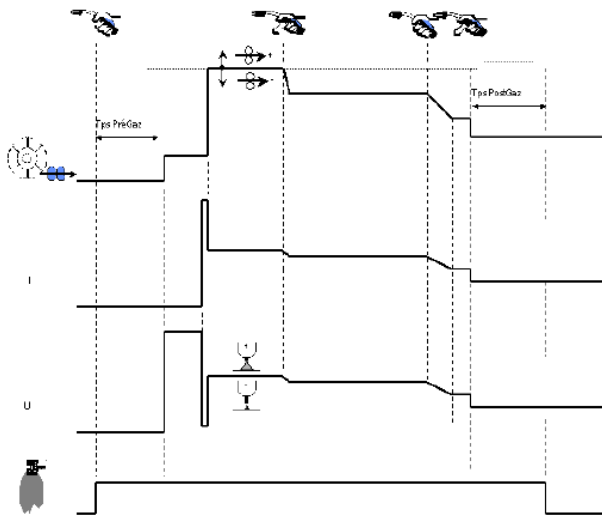

Configuration SETUP:  
SETUP CYCLE HOTSTART  
Hotstart enabled  
SETUP CYCLE sl op down  
Sl op down enabled

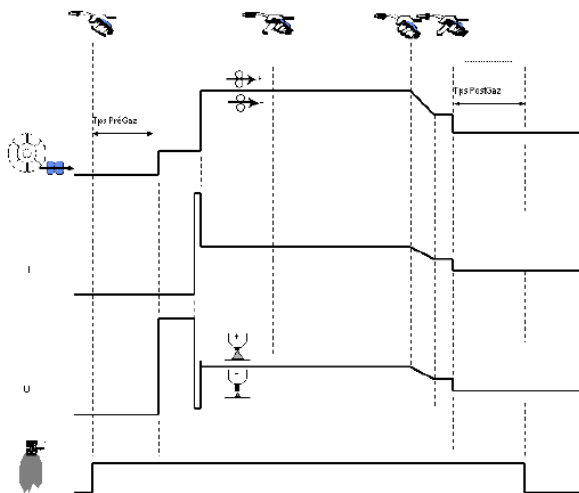

Configuration SETUP:  
SETUP CYCLE HOTSTART  
Hotstart disabled  
SETUP CYCLE sl op down  
Sl op down enabled

4

4

" "

1. 4
2. 4 " = "
3. " "
- ⇒
- ⇒ 1 4
- ⇒
- ⇒ 1, 2, 3, 4
- ⇒ 1, 2, 3, 4
- ⇒ 1, 2, 3, 4
- ⇒ 1 ( )
- ⇒ 1 ( )

/

a) 4

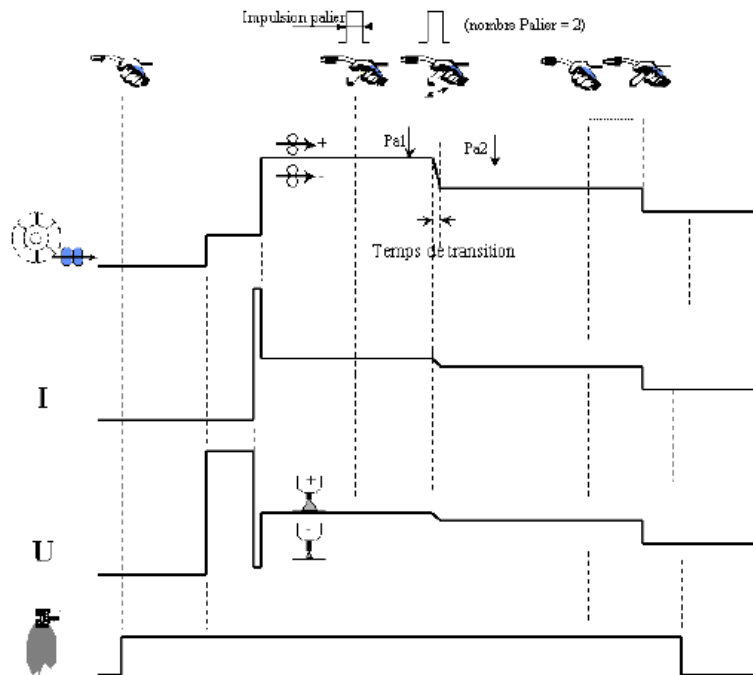

b) 4

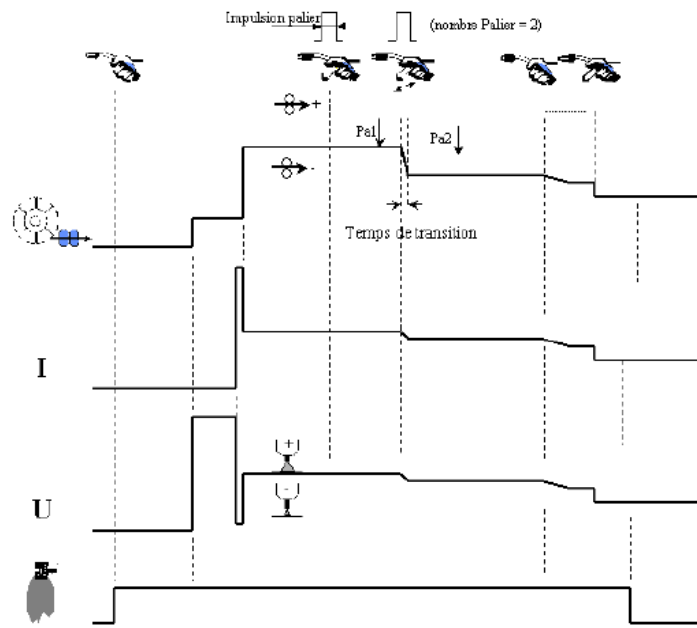

c) 4

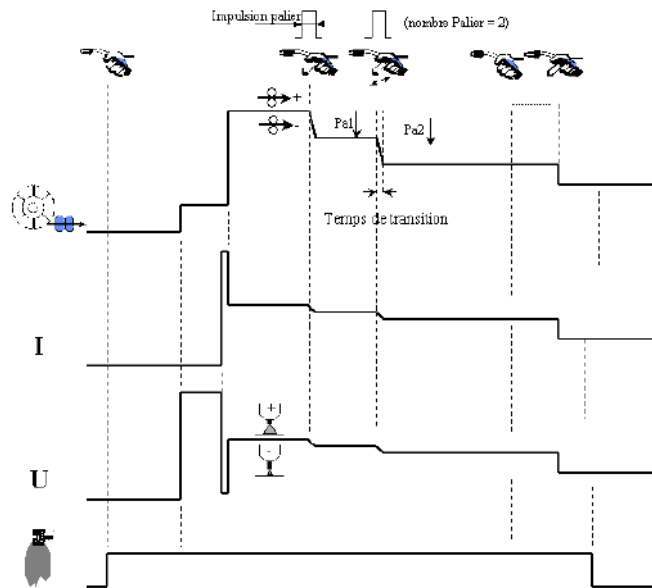

d) 4

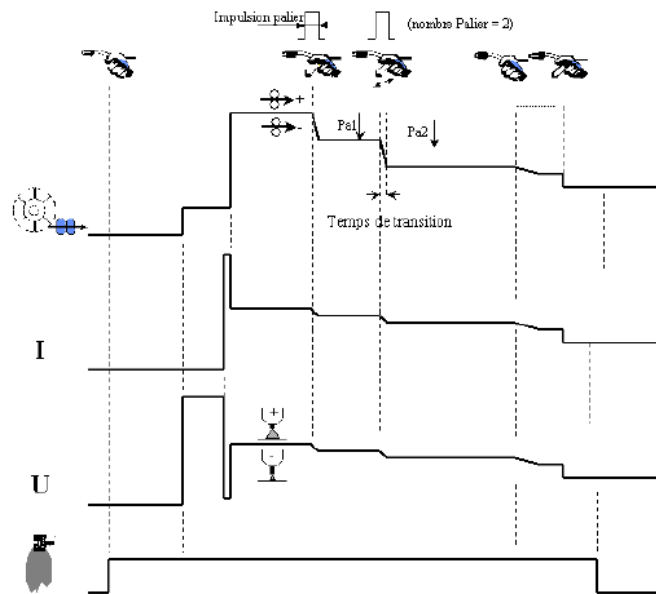

3.6 V000241701



DIGI@WAVE™  
1

DIGI@WAVE™ 280

J3

K de J3	RI
L de J3	RI
T de J3	
L de J3	
U de J3	+
M de J3	-

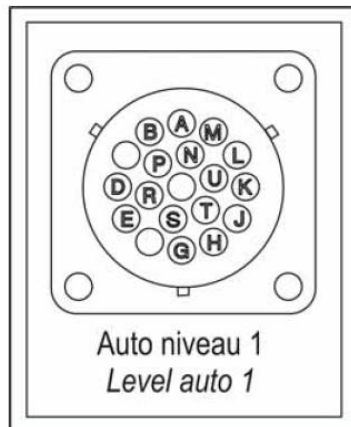

3. 7. N2 REF. V000266590

- 1 - GRE / TRI MTRI O A1 GRE
- 1 - SECU GRE

-

*GR*

A2

	A	O	1	2	3
2				/	
		RI	/	Mt	/ RI
			/		
			/		

RI  
AR

AR

AR

AR

AR  
15A

RI

/

RI



1V 0 10V  
 0  
 1  
 In cons 1 = 0 V  
 In cons 2 = 1 V  
 39  
 In cons 1 = 3 V  
 In cons 2 = 9 V

-50 +50  
 -0V 10V

Uarc 0 100V  
 0 10V  
 0 25r/min  
 0 10V

/  
 a)

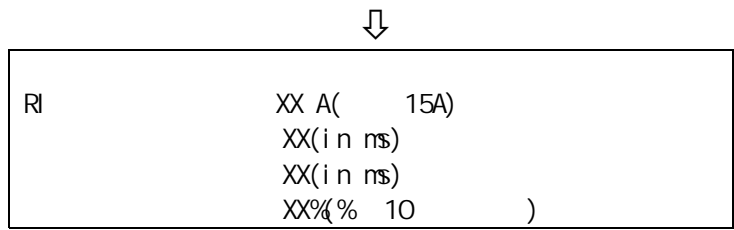
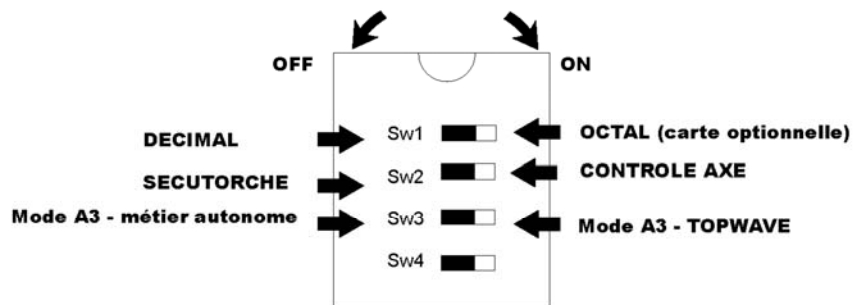

OUT CONS3 0 10V  
 2  
 OUTCONS3 0V 10V

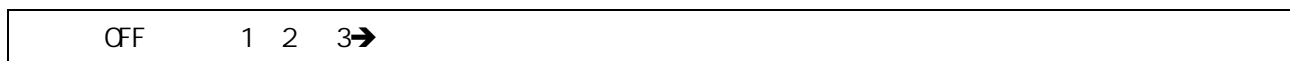

b)

>1s                    5s

<1s                    7s

c)  
I 2

d) NPN    PNP  
I 1            NPN

### 3. 8. PC            REF. V000055081

a)  
PC

MM    PC  
PC    ⇨USB

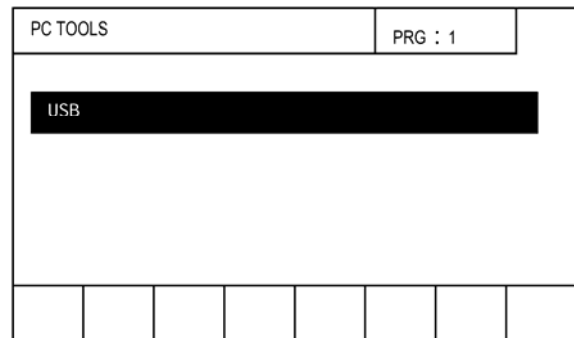
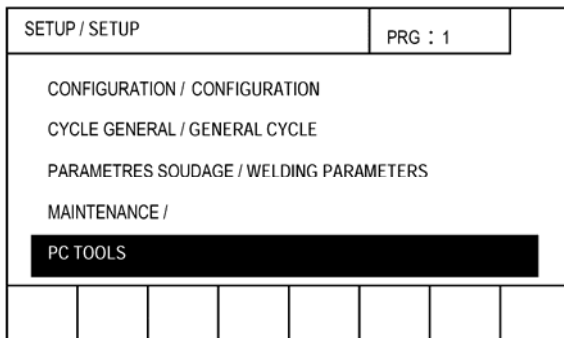

USB

USB

USB  
USB



USB  
USB

USB				PRG : 1			
PROGRAMME / PROGRAM							
CONFIGURATION / CONFIGURATION							

USB

1. \_\_\_\_\_  
0

PROGRAMME				PRG : 1			
SAUEGARDE PROG : N / 0..99							
PROG SAFEGUARD : N / 0..99							
Chargement Prog : Tous / 0..99							
Loading prog : All / 0..99							

OK

✓  
✓

AA, AB, ....., AZ, BA, ...,

PC

\_\_\_\_\_

OK

✓  
✓

PXX

XX OO 99

23	10	06	AA	POO
----	----	----	----	-----

2. \_\_\_\_\_  
0

CONFIGURATION				PRG : 1			
Sauvegarde Config. : Oui / Non							
Config. Safeguard : yes/no							

-----Sauvegarde/Chargement sur USB----- ____backup/loading on USB____
Fichier/file : 231006AA.CFG Date : 23/11/06 14 :30
APPUI SUR OK POUR SAUEGARDER / CHARGER PRESS OK TO BACK UP / LOAD

- ✓
- ✓
- ✓
- ✓

AA, AB, ....., AZ, BA, ...,

PC

OK

CFG

23	10	06	AA	CFG
----	----	----	----	-----

3. 9. MIXAL REF. V000055037

- A3
- 
- 

a) nuxal

1.

- ⇒ " JCB RC " V000055077
- ⇒ " JCBNATI C" V000264590

2.

- " CAD " 5m V000055040
- / 24V DC

3. PROG

### PRISE BAIE COMMANDE

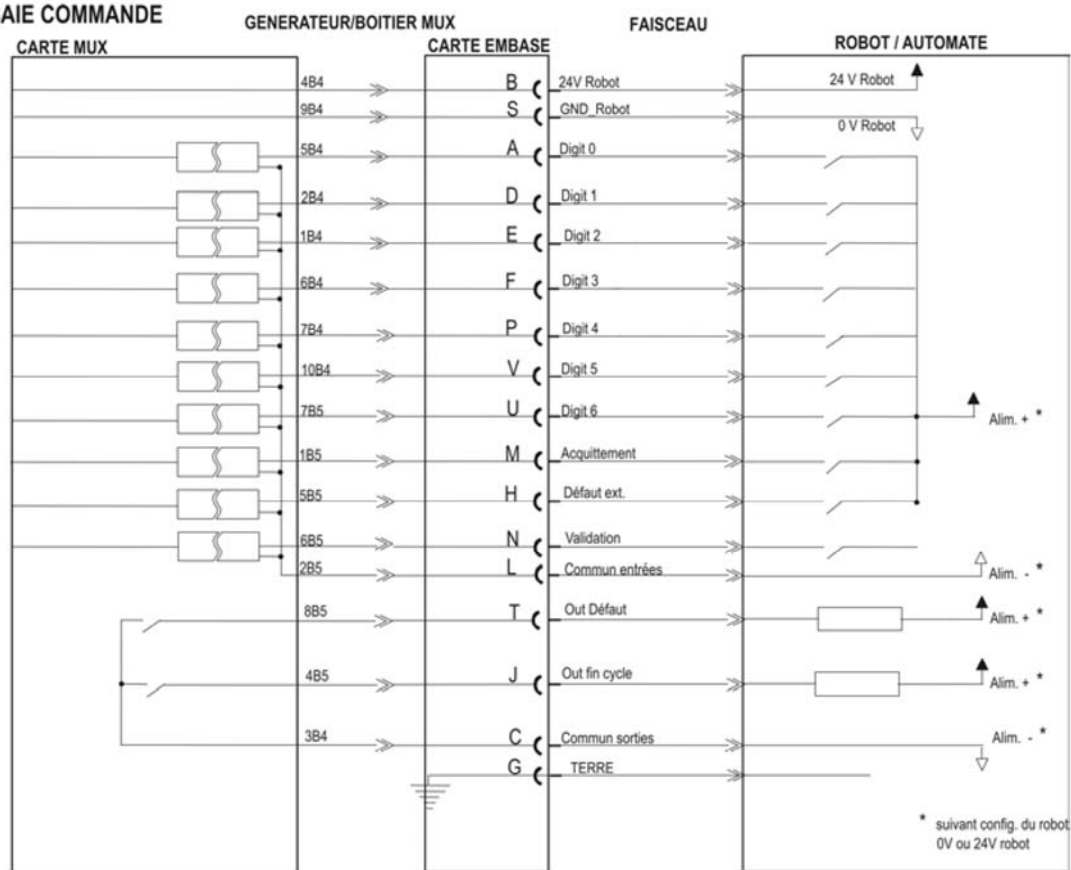

7

DIGIT0 DIGIT6

99

DIGIT0	DIGIT1	DIGIT2	DIGIT3	DIGIT4	DIGIT5	DIGIT6	N° prog
0	0	0	0	0	0	0	0
1	0	0	0	0	0	0	1
0	1	0	0	0	0	0	2
1	1	0	0	0	0	0	3
0	...	...	...	...	...	...	...
1	...	...	...	...	...	...	...
0	1	1	1	1	0	1	95
1	0	0	0	0	1	1	96
0	0	0	0	0	1	1	97
1	1	0	0	0	1	1	98
0	1	0	0	0	1	1	99

4.

1m/min

**PRISE METIER**

**GENERATEUR/BOITIER MUX**

**FAISCEAU**

**ROBOT / AUTOMATE**

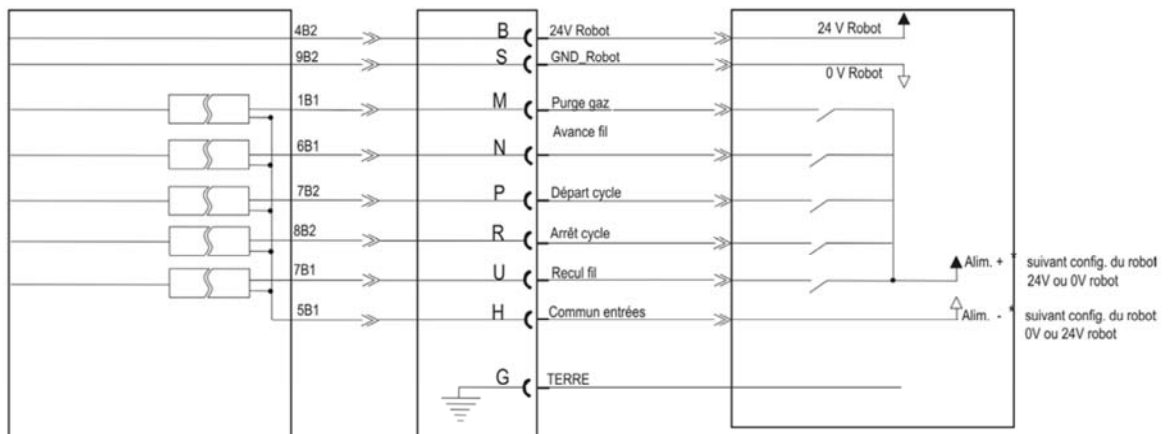

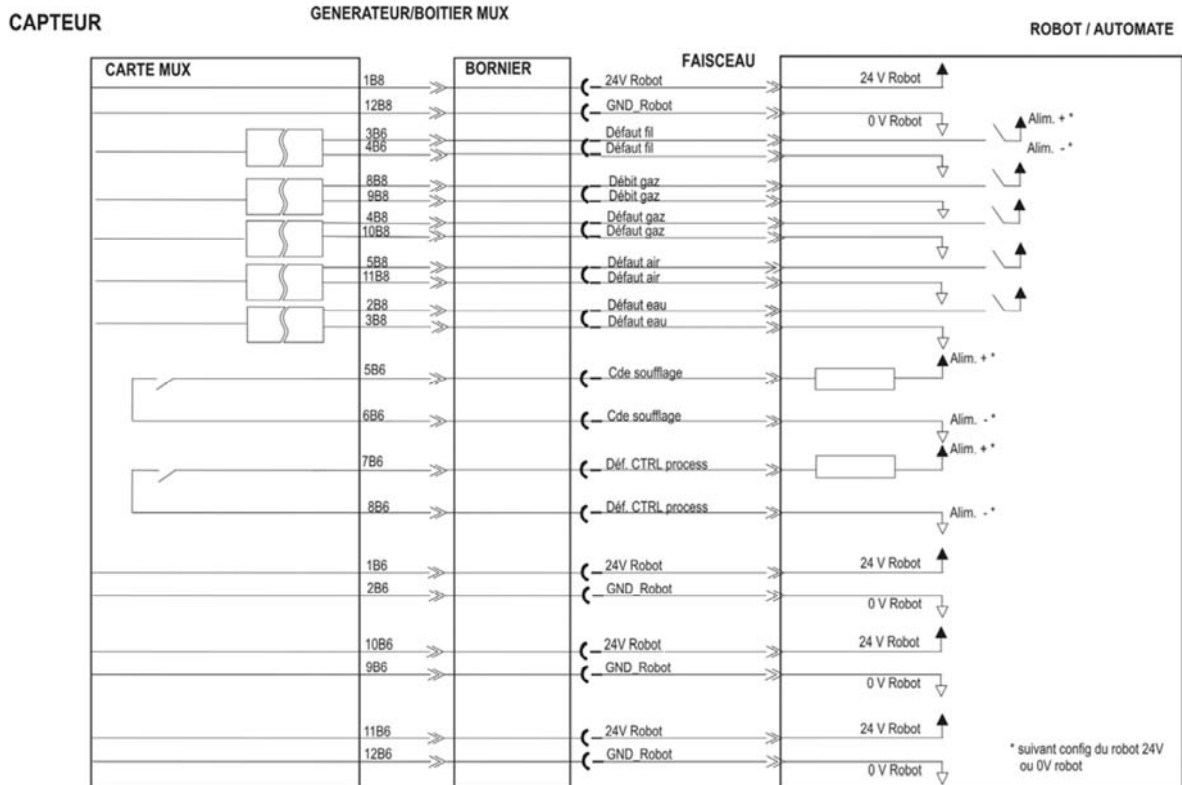
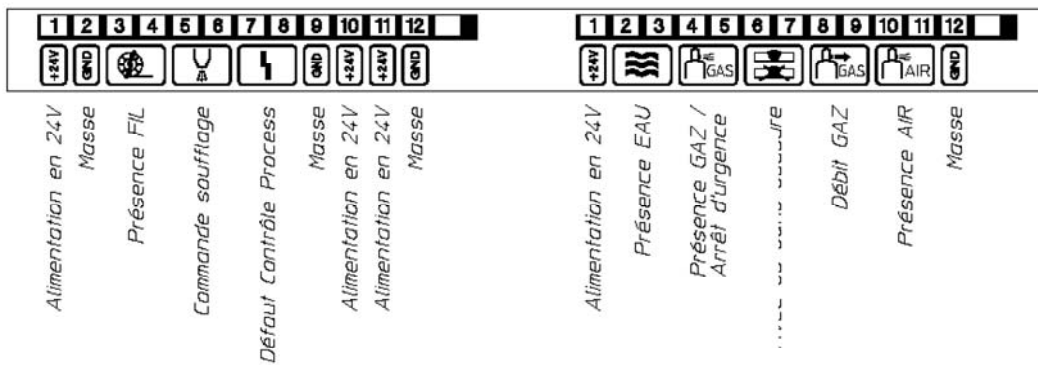

b) /

- NPN PNP
- MIX N3
- RI

1



MUX

- 1
- 2
- 3           "       "
- 4           "       "
- 5           "       "
- 6           "       "
- 7           "       "
- 8           "       "
- 9           "       "
- 10-11-12

0→6 Inc

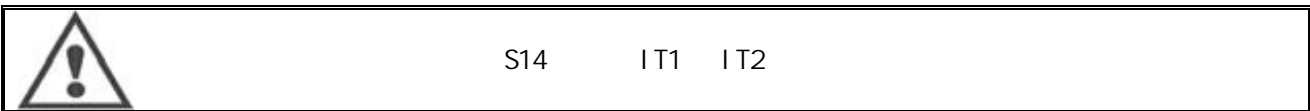

3. 10.

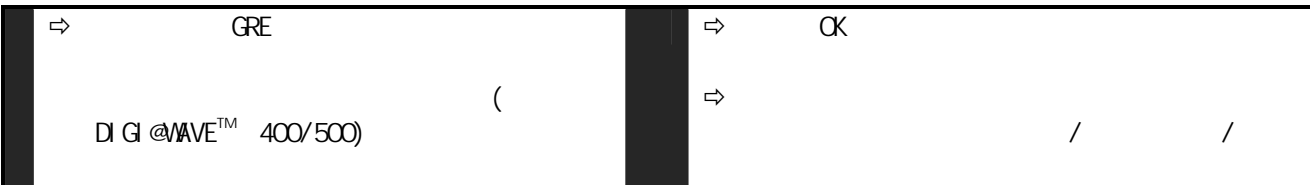

⇒ ⇒ ⇒	⇒ ⇒ ⇒	+ 4	OK
-------------	-------------	-----	----

⇒	OV OA	ALW
---	-------	-----

⇒	⇒	OK
---	---	----

⇒ ⇒ ⇒	⇒	OK
OK	⇒	OK
	⇒	OK

3. 11.      500CDR      V000055083



	DI GI @WAVE 500
--	-----------------

3. 12      DVR 500      V000055087



2 " Choc Torch"  
 " Choc Torch"  
 A2

>1s 5s

<1s 7s

" " 400mA / 24VDC  
 " "



Cas NPN

NPN configuration

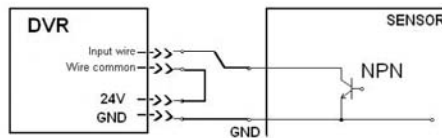

Cas PNP

PNP configuration

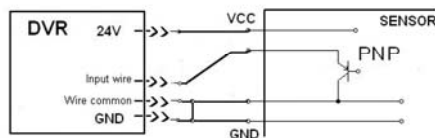

" " 400mA  
 " " 400mA

PP+ / PP-



DIGI@WAVE 500

3. 13.  
DVR 500

DV-R 600 HD

V000055068



3. 14.

- 2 m ref. V000055088
- 5 m ref. V000055089
- 10 m ref. V000055090
- 2 m ref. V000055091
- 5 m ref. V000055092
- 10 m ref. V000055093
- 15 m ref. V000055094
- 2 m ref. V000055095
- 10 m ref. V000055096
- 15 m ref. V000055097
- 25 m ref. V000055098

### 3. 15.

ANNEX 3-4

a)

A		95mm <sup>2</sup> -H01N2-D	19	
B	A1			
C	CAD	CAD	10m	7
E	A2			
F	<del>TOPWAVE</del>	A3		
G	DVR500			
H	DVR500			
J	MIXAL	"	"	
K	MIXAL	"	"	
L		CAD	CAD	5m 7
M	DV-R600	"	"	
N	DV-R600	"	"	
R	MIXAL STD			

b) TRI MTRI O MINI FI TS

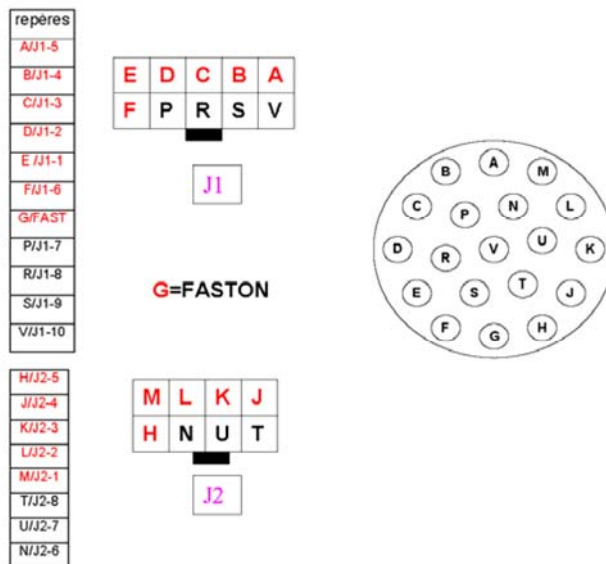

### 3. 16 (DIGI@WAVE 280)

PROMIG NG 241 3m ref. V000345060

DIGI@WAVE



PROMIG NG 241 4 m ref. V000345061

PROMIG NG 241 5M ref. V000345062

PROMIG NG 341 3M ref. V000345066

PROMIG NG 341 4M ref. V000345067

PROMIG NG 341 5M ref. V000345068

### 3. 17. (DIGI@WAVE TM100)

PROMIG 441W 3 m ref. V000145256

PROMIG 441W 4 m ref. V000145257

PROMIG 450W 3 m ref. V000345052

PROMIG 450W 4 m ref. V000345054

### 3. 18 (DIGI@WAVE 500)

PROMIG 450W3m ref. V000345052

PROMIG 450W4 m ref. V000345054

PROMIG 450W5M ref. V000345057

PROMIG 501W3M ref. V000345058

PROMIG 501W4M ref. V000345059

PROMIG NG 441W3M ref. V000345075

PROMIG NG 441W4M ref. V000345076

PROMIG NG 441W5M ref. V000345077

### 3. 19.

ALUTORCHE DG342 - 10M ref. V000264913

ALUTORCHE DG441W- 10M ref. V000265067

DI GI TORCH PP 352 - 8M45° , ref. V000267606

DI GI TORCH PP 451W- 8M45° , ref. V000267607

DI GI TORCH PP 451W- 8M0° , ref. V000271006

3. 20. REF. V000055077

- 1
- 2
- 3
- 4
- 5



3. 21. CAD REF. V000055040  
CAD

3. 22. REF. V000055046



3. 23. REF. V000055048

180°



3. 24.

. V00005501

5 HM16x6

1  
2  
3

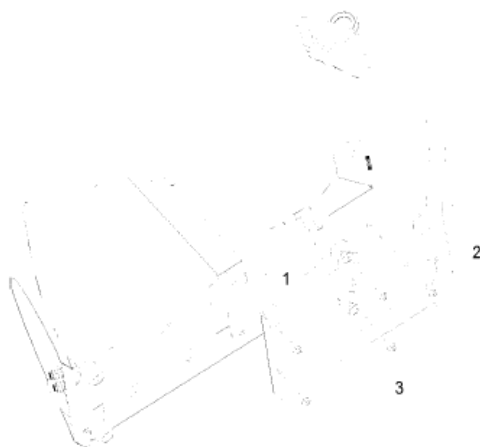

3. 25.

REF. V000345009



1  
2

3. 26. A1

REF. V000241701

DGM280



3. 27.

CAD REF. V000264590

CAD

/

3. 28.

REF. V000055061

3. 29.

REF. V000264842

3. 30.

REF. V000261664

TRI MTRIO

5

N1

4

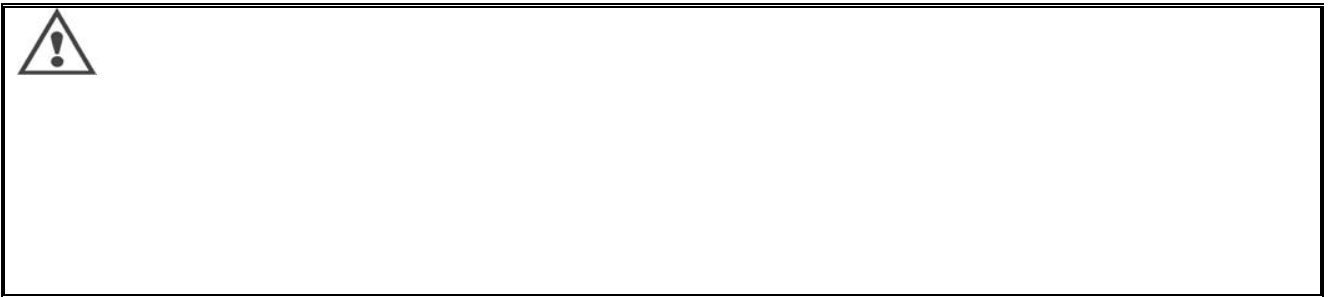
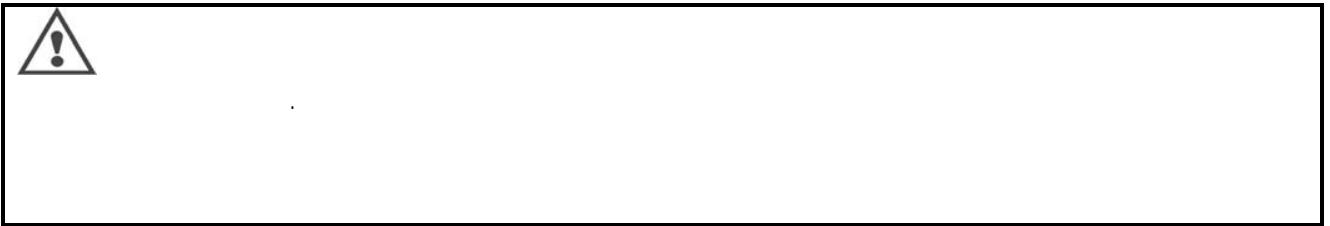

4.1.

4.2



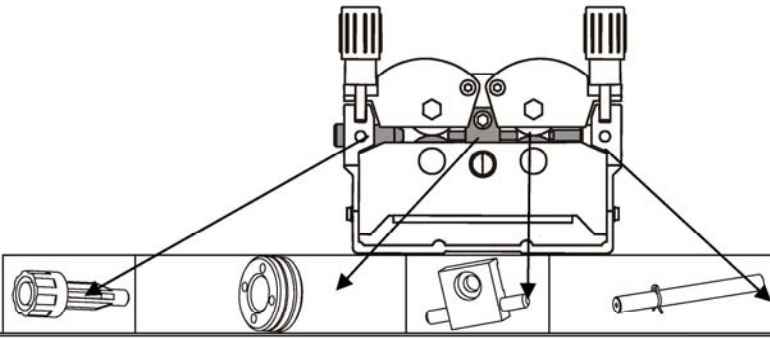

		ALUKIT			
acier steel	0,6	W000305150	W000305125	W000162834	W000255654
	0,8		W000267598		W000241685
	1,0		W000267599		W000255655
	1,2		W000305126		W000241682
	1,6				
Alu	1,0 / 1,2		W000260185		W000255648
	1,2 / 1,6		W000260186		W000255649
	1,6 / 2,4		W000260187		W000255650
Fil fourré é	1,0 / 1,2 1,2 / 1,6	W000305150	W000266330	W000162834	W000255655 W000241682
	Cor ed wire	1,6 / 2,4	W000257395	W000266331	W000257397

### 4. 3.

- ⇒
- ⇒
- ⇒
- ⇒

- ⇒ SPRAYMIG SI B, W000011093
- ⇒ SPRAYMIG H2O, W000010001

5 /

5.1.

(2)

1 2 3 4)

	V00055011	V000055015	V000055020	
	DI GI @WAVE 280	DI GI @WAVE TM400	DI GI @WAVE 500	
A	V000241692	V000241692	V000241692	DTW ALW
10-11	V000231163	V000231163	V000231163	f isol. rac. rap. 400a
12-15	V000241702	V000241702	V000241702	+
13	V000148730	V000148730	V000148730	
13	V000157026	V000157026	V000157026	
14	V000147188	V000147188	V000147188	10a 1p + ( )
20/21	V000241696	V000241696	V000241696	13 to 18 pg16 +
	/	/	/	pg16
22	V000241698	V000241698	V000241698	32a 90 3
23	V000241699	V000241699	V000241699	+
24	V000154986	V000154986	V000154986	m12 l 25 rod
25	V000241704	V000241704	V000241704	+
31*	V000241695	V000241695		- DGW 400
*	/	/	/	- DGW 500
32*	/	V000241694	V000241694	60c he10 0.09mm2 l 250
33	/	V000148018	V000148018	- 16 std
34	V000147530	V000147530	V000147530	
35	/	V000241700	V000241700	
36	/	V000241701	V000241701	1
37	V000241703	V000241703	V000241703	- m22 290va
38	/	V000148702	V000148702	5L +
39*	V000241705	V000263177	V000263177	
40	/	V000148195	V000148195	‡ 200
41	/	V000241706	V000241706	400v AC
42	V000260728	/	/	60che10 0.09mm2 L = 380
43	V000148699	/	/	EMB L 45
44	V000162550	/	/	600A

45	V000147358	/	/	28mm di a. ¼
46	V000155003	/	/	40mm x 40mm
47	V000260729	/	/	DGW 280
48	V000260730	/	/	DGW 280
49	V000241664	/	/	
50	V000148727	/	/	24 VDC
51	V000149075	/	/	
52	V000255656	/	/	, PA 4G Ø 37 CYL,
53	V000241680	/	/	
54	V000241681	/	/	66 mm
55	V000148658	/	/	2
56	V000148661	/	/	
57	V000163284	/	/	/ U
58	V000255651	/	/	+
60	V000255653	/	/	
		V000010167	V000010167	FREEZCOOL 10 L
		V000010168	V000010168	FREEZCOOL 20 L



	CHARI OT ATELI ER VORKSHOP DI GI @WAVE V000055046	CHARI OT DEVI DCI R TROLLEY WRE FEED DI GI @WAVE V000055050	
	V000147074 V000148249		300 125
		V000147075 V000147076	200 65

5.2

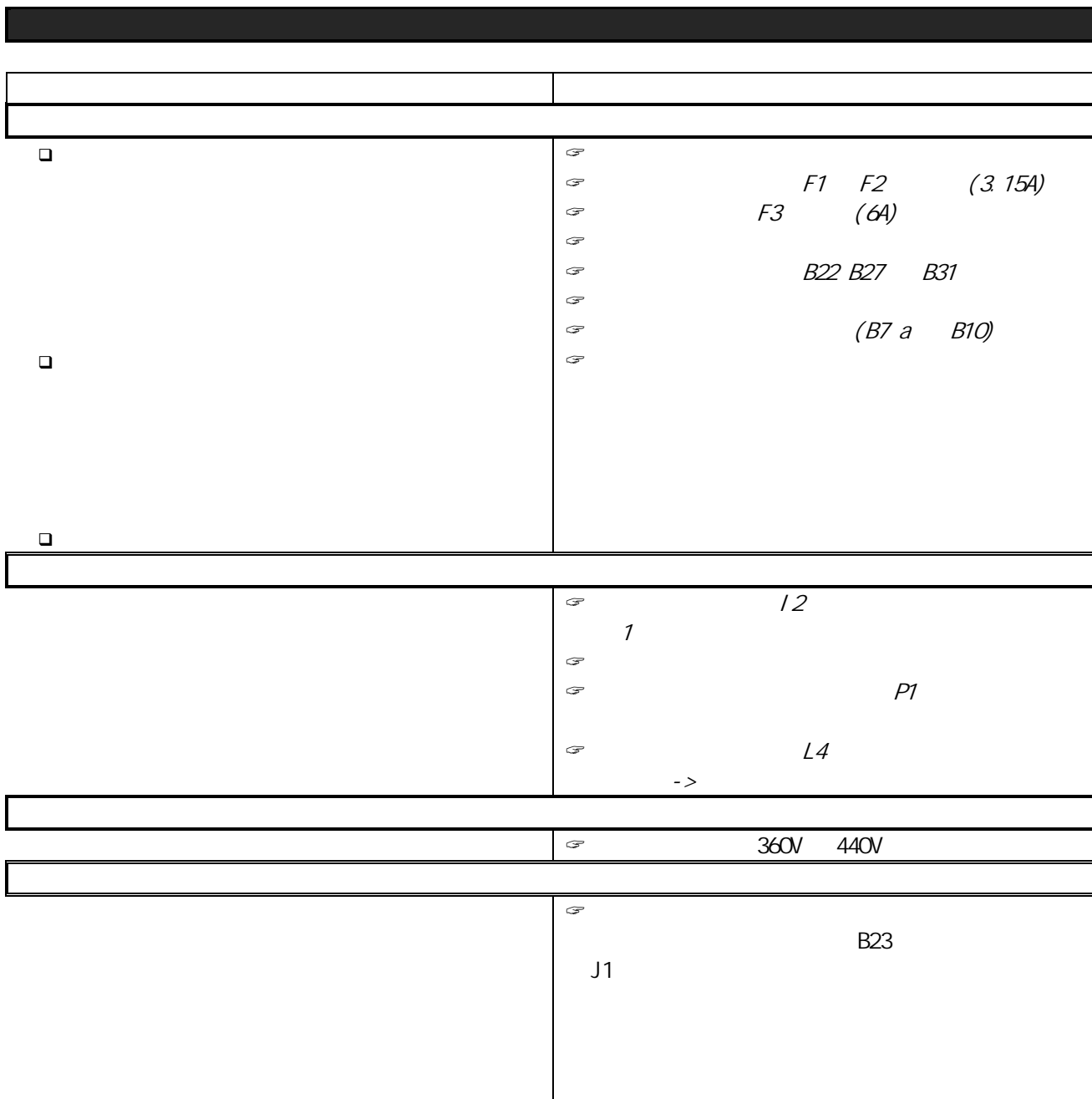

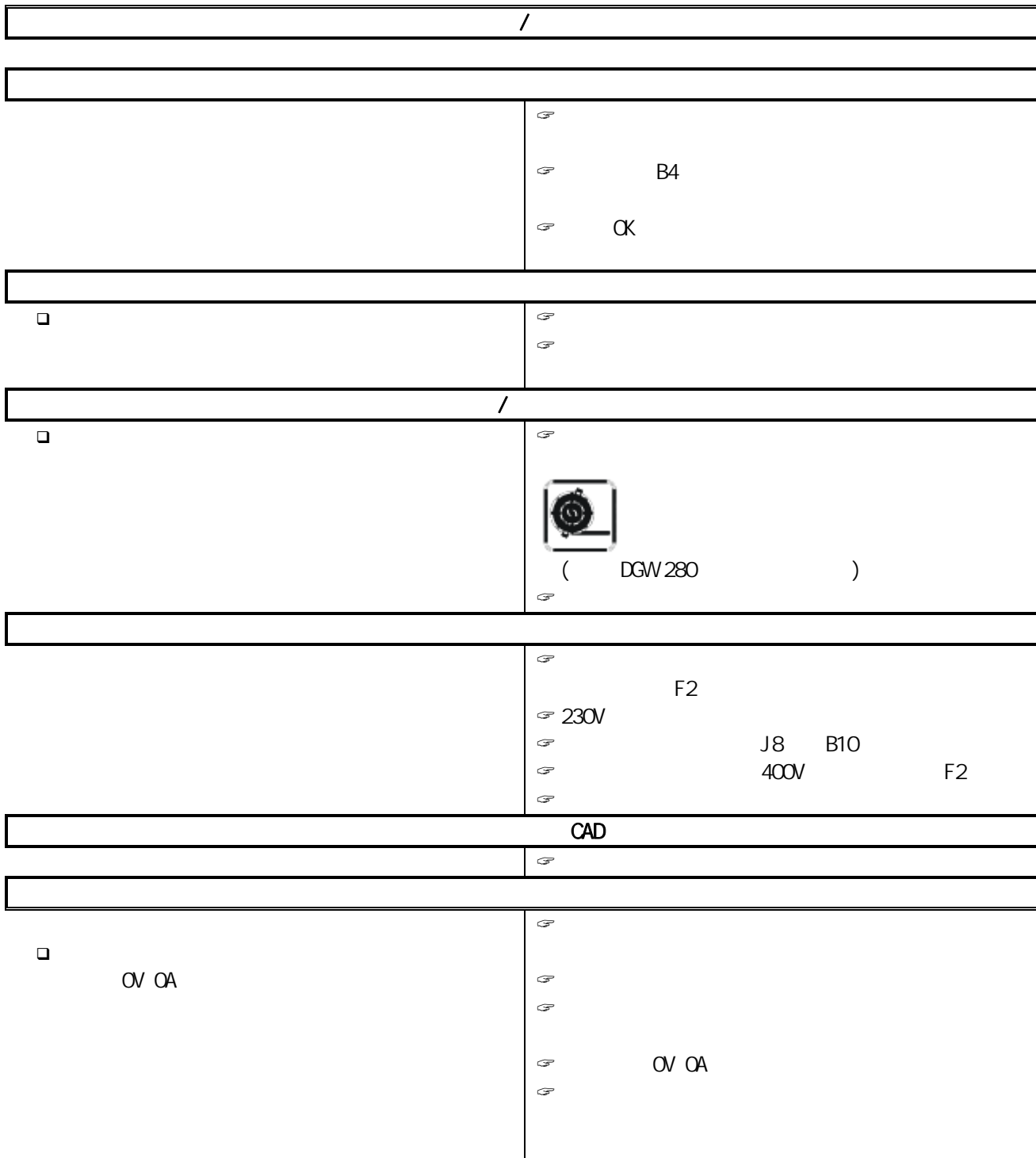

□

⊗

LED

⊗

L1

MIG

2T

L3

L3

⊗

PCB

- L4

- L6

- L13

- L7

- L9

- L12

- L10 (5V)

- L3

B27

⊗

F3 6A

24V AC



□

⊗

" Regl age Fi n"

□

(RFP = 0)

R L

R, L O

( )

□

Lg

50

⊗

⊗

⊗

AdU Adl

O

⊗

⊗

⊗

⊗

⊗

⊗

⊗

⊗

⊗

⊗

□

□

□

□

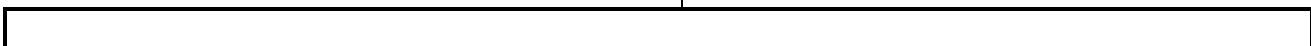

□

⊗

⊗

⊗

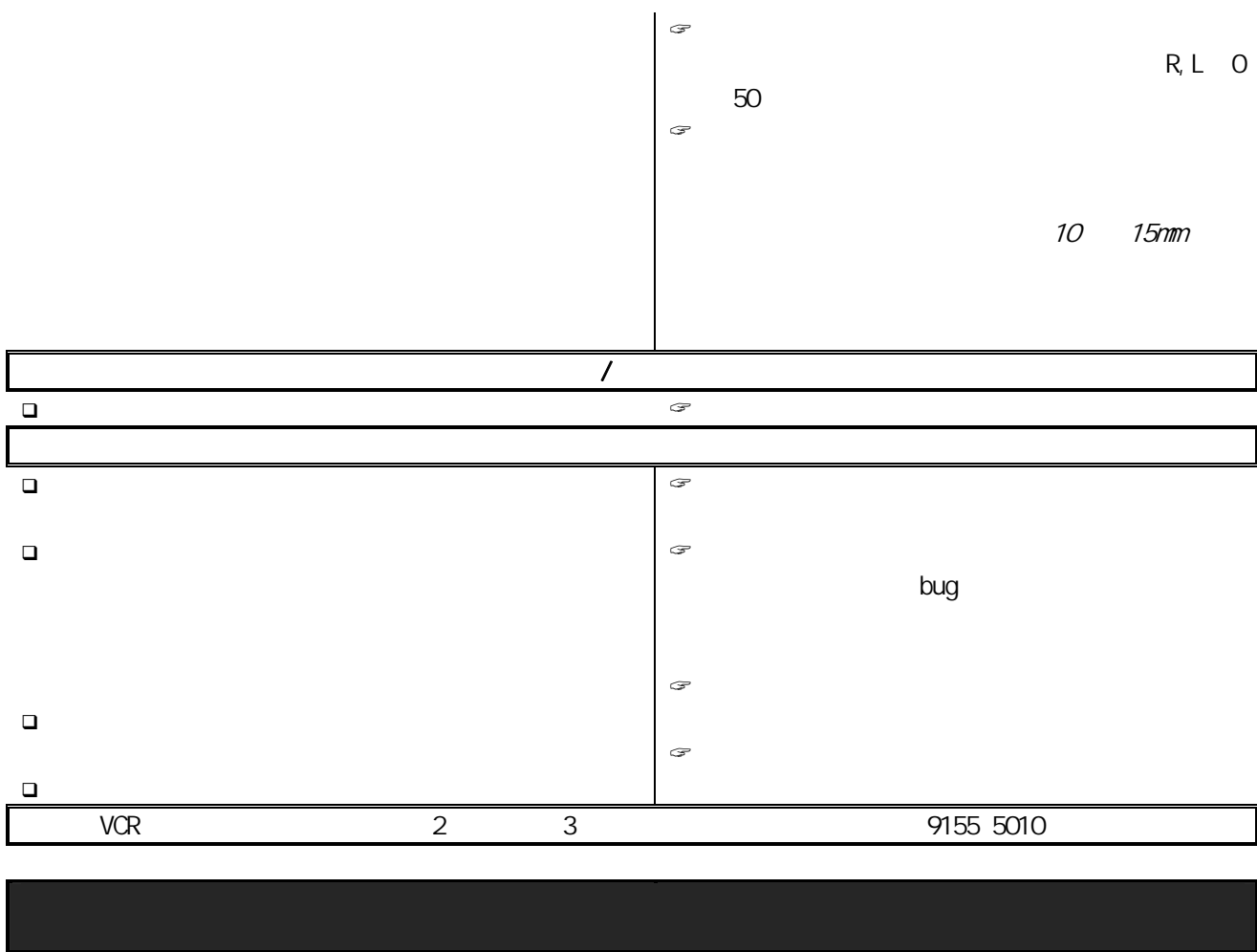



(DI GI @WAVE™400/500)

<input type="checkbox"/> <input type="checkbox"/>   <input type="checkbox"/>	☞ F1 ☞ ☞ B23 I 1 ☞ B43 B56 ☞ I 1 ☞ L4 L2 ☞
--	--

(DI GI @WAVE™400/500)

CAN

<input type="checkbox"/>	☞ ☞ J1 J1 B23 B43 ☞ ☞
--------------------------	--------------------------------

<input type="checkbox"/>	☞ B54 ☞ MOT+ MOT-
--------------------------	----------------------

	☞ ☞ ☞ ☞ ☞
--	-----------------------

" No motor vol tage"

<input type="checkbox"/>	☞ F2 ☞ B24 J2 ☞ (DGW 400/500) ☞ B40 ☞ J2 (DGW 400/500) ☞ 42V
--------------------------	---





	GB
1	LEVEL 1 AUTOMATION
	CONTROL AND SETTING CARD
3	3-PHASE FILTER CARD
	SETTING
	GAS BLEED AND WIRE FEED CONTACT
	UNBALANCE
	STANDARD HARNESS
1-3	FER1-3 PASSES
/	GRID / SOURCE
	GRE LINK
	AUXILIARY TRANSFORMER CONNECTION
" I PRIM	" I PRIM MEASUREMENT ON CONTROL CARD
	SECONDARY VOLTAGE MEASUREMENT, MICRO
	FRONT PANEL CONNECTION
/ MIN FIT	MALE / FEMALE MIN FIT
	PRELOAD
	WRAP-AROUND
	COOLER
	PARAMETER RESET

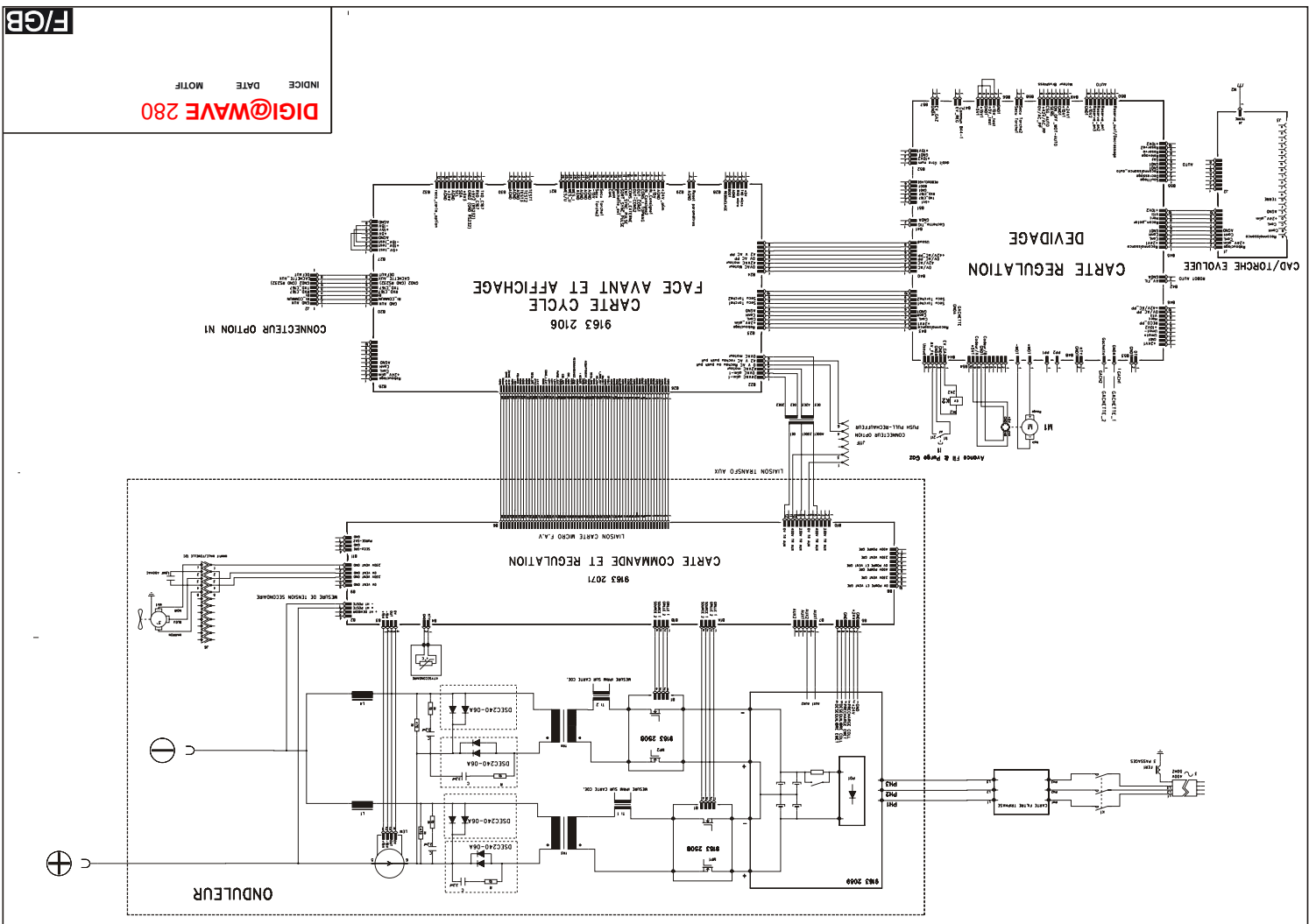

INDICE DATE MOTIF  
**DIGI@WAVE 280**

F/GB

1

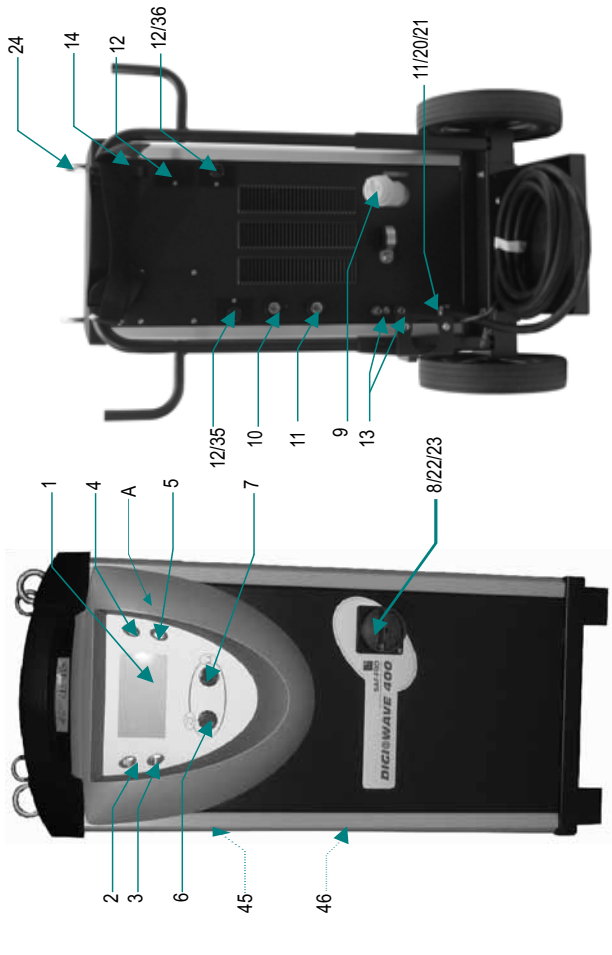
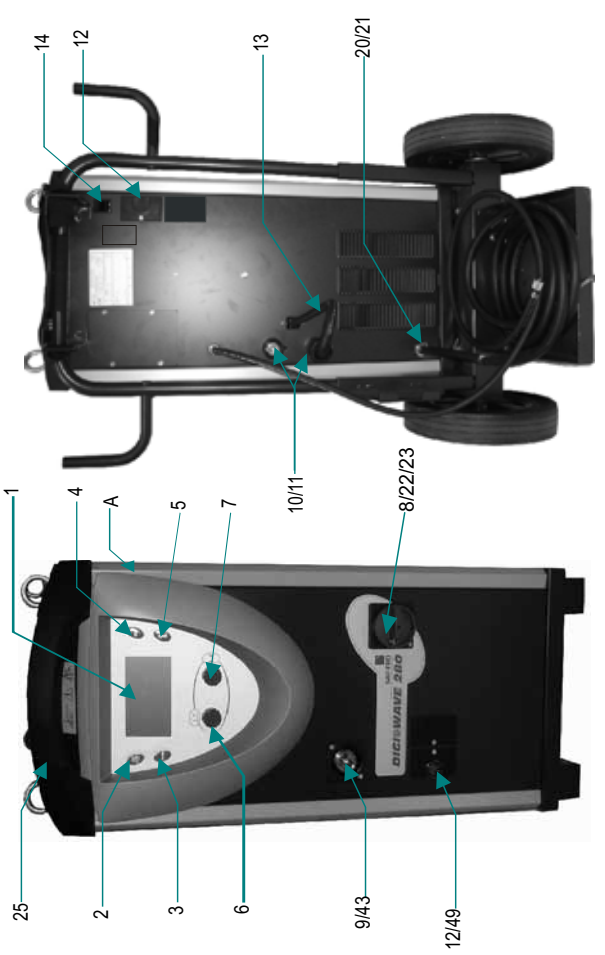

DIGI@WAVE TM 400

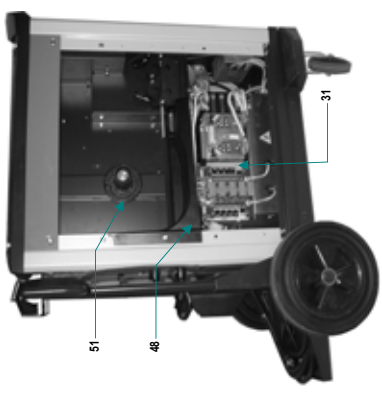
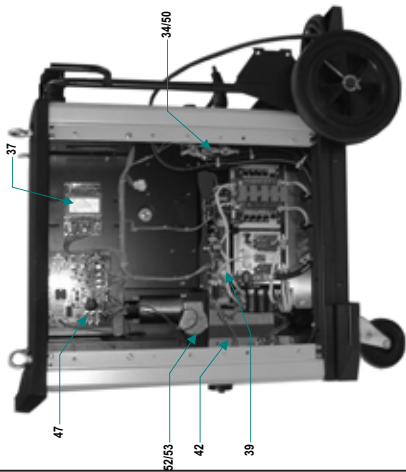
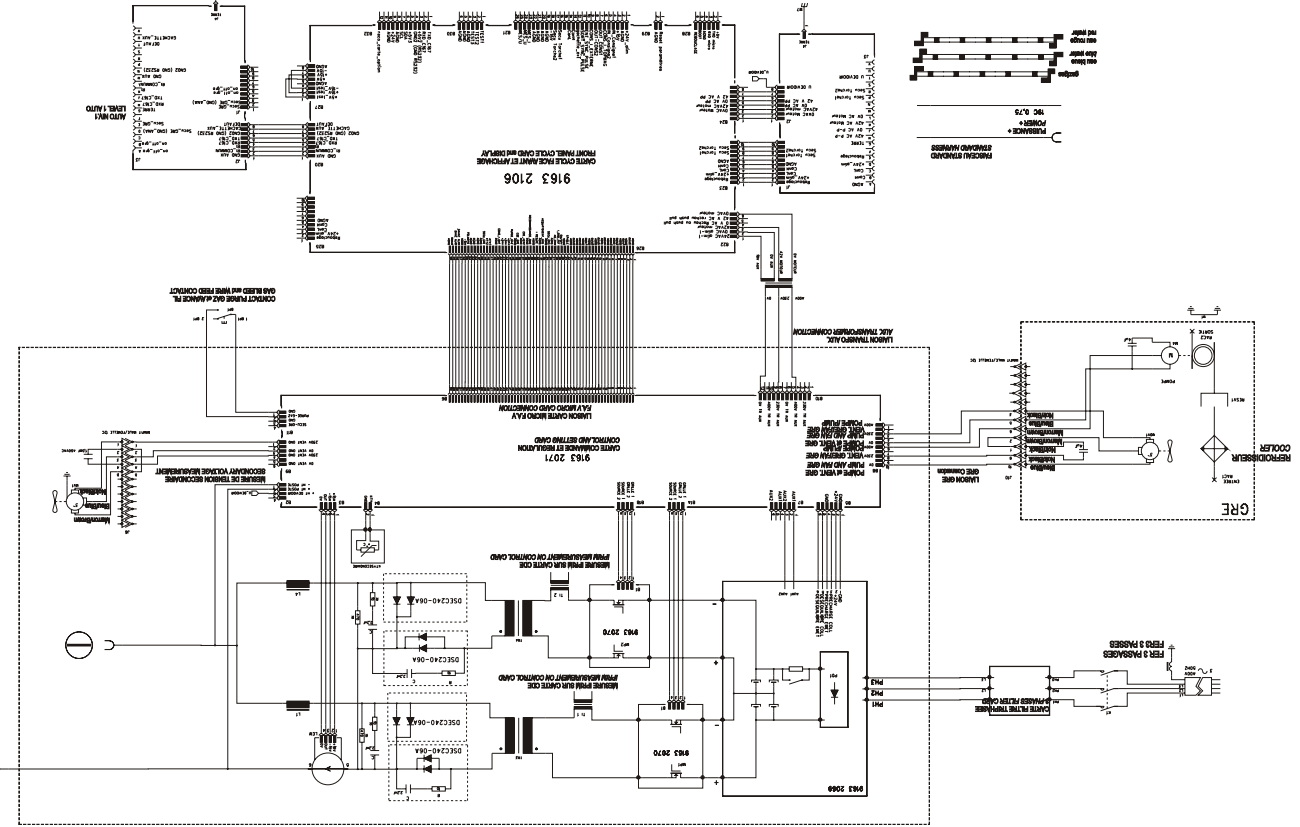

DIGI@WAVE TM400

